

# Antennas

One of the most important considerations when operating a radio is the type of antenna to be used. For good communications with a radio operating in the HF range (2.000 kHz to 29.999 MHz), you must consider the--

- Type of antenna.
- Operating frequency.
- Terrain around the radio site.
- Time of day.
- Location of and distance between radios.
- Atmospheric conditions.

The operator can sometimes control the first four or five factors. The antenna and frequency are the most important considerations under his control. Both should be selected to suit the distance between the radios and the propagation characteristics. The operator will most likely have two or three different frequencies assigned for the operation or exercise. These will be found in the SOI under the net in which he is operating.

## Section I. Antenna Selection

a. The field environment, tactical situation, and distance between radio sites determine the type of antenna used. If the radio set is used while on the move, the whip antenna supplied with the equipment is normally used. The whip antenna, using the ground wave, is satisfactory for most short-range missions.

b. If the tactical situation permits, a simple half-wave dipole antenna (doublet) or the NVIS antenna is used to extend the range of the radio by using the skip phenomenon. Skip means the radio waves are bounced off the ionosphere and back to earth giving coverage of 300 miles or more. [Figure 3-1](#) shows the ground wave and sky wave using the skip phenomenon. The NVIS can be used at frequencies above 12 MHz but automatic tuning of the radio (AN/PRC-104A and/or AN/GRC-213) may not be possible at all frequencies.

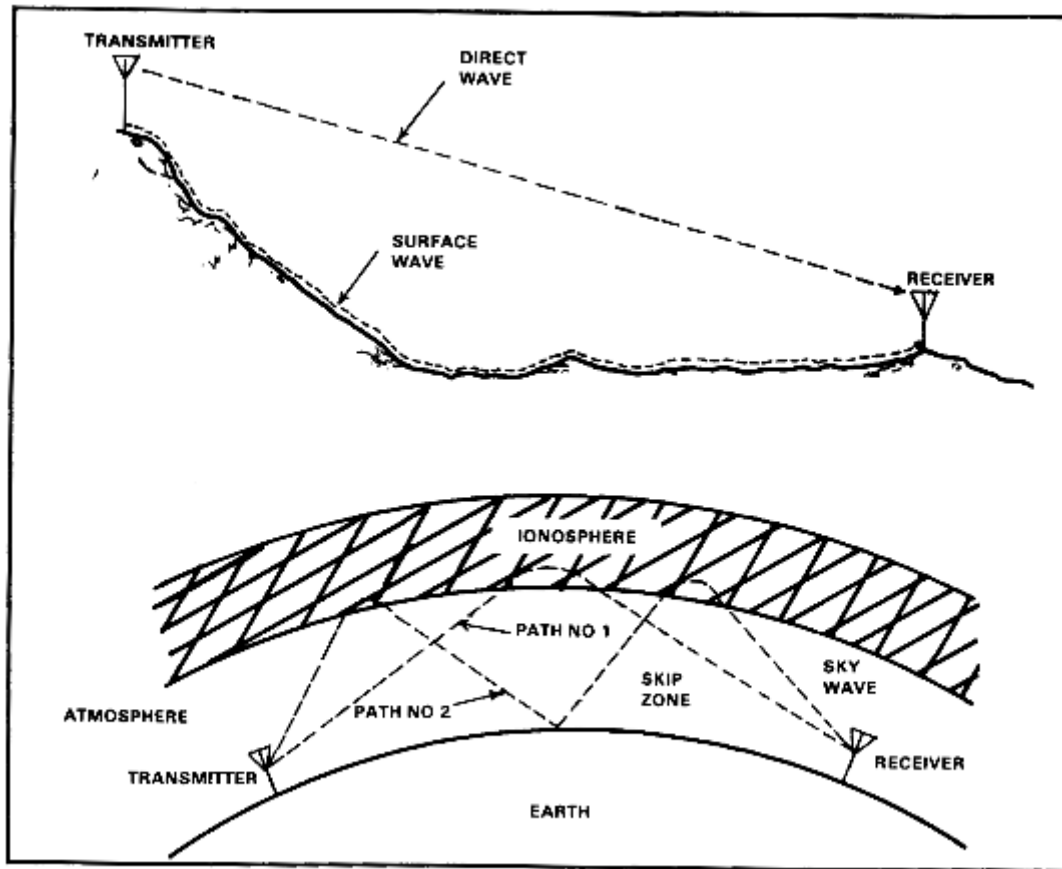

Figure 3-1. Sky-wave and ground-wave propagation.

c. When using an antenna with directional characteristics, orient the antenna so that it is most sensitive in the direction of the other station(s). [Figure 3-2](#) shows the radiation pattern of the antennas.

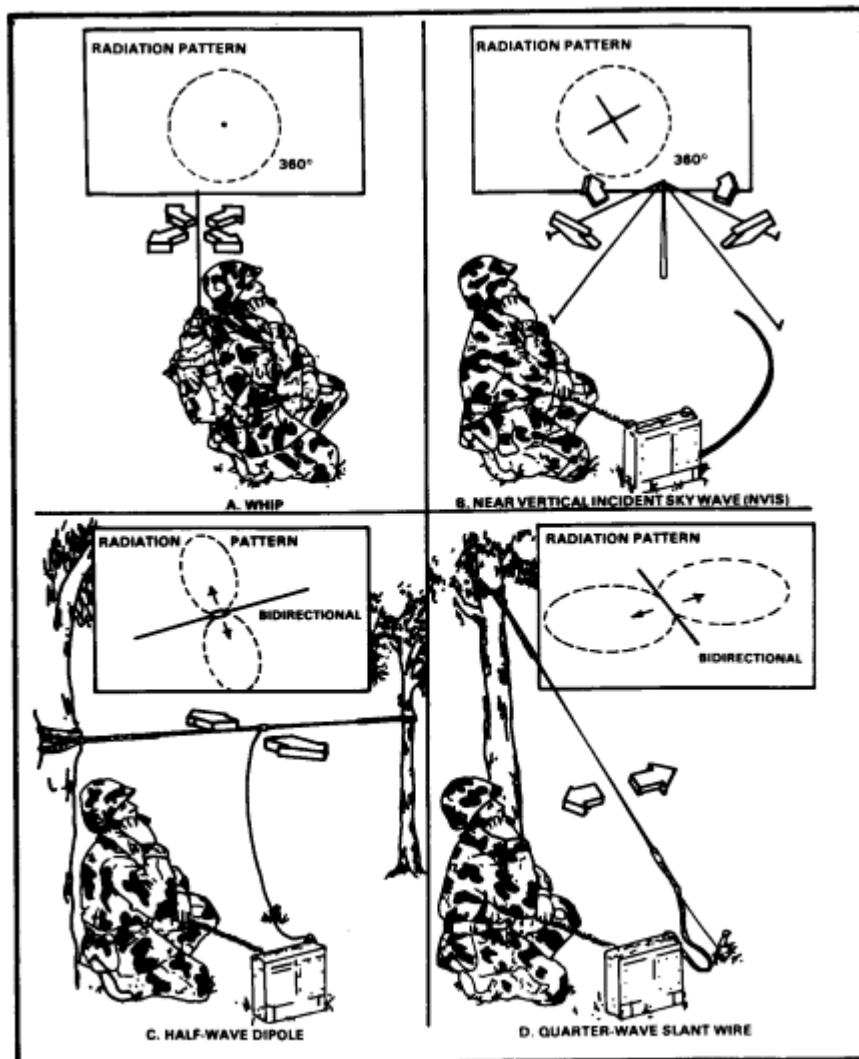

Figure 3-2. Antenna radiation patterns.

d. [Standard and optional antennas](#) that can be used with IHFRs are listed below.

- WHIP ANTENNA                      Omnidirectional (360-degree radiation pattern).  
Easily and quickly assembled and erected.  
Lightweight and easy to carry.  
Limited range (10 miles or less) over land.
- AS-2259/GR (NVIS)                Omnidirectional.

- Requires large clear area (80 feet square) for proper erection.

Long range (0 to 300 miles).

• HALF-WAVE DIPOLE DOUBLET      Bidirectional (broadside to wire).

Good portability.

Quickly assembled and erected. Requires two or more vertical supports (trees, poles).

Extended range (to 300 miles and beyond).
- QUARTER-WAVE SLANT WIRE      Bidirectional (broadside to wire).

Good portability.

Quickly assembled and erected. Requires only one vertical support (tree or pole).

Range up to 1,000 miles.

NOTE: These are a few of the antennas that can be used.

## **Section II. Whip Antenna**

a. When using a quarter-wave or whip antenna, ground the antenna to increase its effectiveness. Using this characteristic of the ground, an antenna a quarter-wavelength long can be made into the equivalent of a half-wave antenna. If such an antenna is erected vertically and its lower end is grounded, the ground takes the place of the missing quarter-wavelength, and the reflections supply that part of the radiated energy normally supplied by the lower half of an ungrounded half-wave antenna.

b. The antenna is grounded by grounding the vehicle itself. Use a ground stake at least 4 feet long, a hammer, and a ground strap. You may substitute a steel reinforcing rod, a steel fence post, or a metal water or gas pipe cut to the right length for the ground stake. Ensure paint and rust are removed from such items. Substitutes for the ground strap include battery cables or any heavy gauge wire. Do not use Field Wire WD-1 because it does not provide a suitable ground. Drive the ground stake into the ground until the top of the stake is 2 to 4 inches above the ground. Attach one end of the ground strap to the stake and the other end to the vehicle body. Ensure all paint and rust are removed from connecting point of the vehicle body to allow a good metal-to-metal contact.

c. When a whip antenna is mounted on a vehicle, the metal of the vehicle will affect the operation of the antenna. As a result, the direction in which the vehicle is facing may also affect transmission and reception, particularly of distant or weak signals. A vehicle with a

whip antenna mounted on its left rear side transmits its strongest signal in a line running diagonally from the antenna through the right front side of the vehicle. Similarly, an antenna mounted on the right rear side of the vehicle radiates its strongest signal in a direction diagonally toward the left front side. In some cases, the best direction can be determined by driving the vehicle in a small circle until the best reception is obtained.

### Section III. Antenna RC-292

Antenna RC-292 is used to extend the distance range of the old and new generation of FM field radio sets. The antenna consists of one vertical radiating element and three ground plane elements. The lengths of these elements are determined by the operating frequency of the radio set. Refer to the antenna element selection chart at [Table 3-1](#). The antenna is elevated on a 30-foot sectional mast which in turn is held erect by guy ropes and stakes. When the operating frequency is changed, check the antenna element selection chart. If the new frequency requires a change in element length, lower the antenna and add or subtract the required number of elements.

Radio Set or Receiver-Transmitter	Operating Frequency (MHz)	VERTICAL				GROUND PLANE					
		Total Number of Antenna Sections Required	Type of Sections Used				Total Number of Ground Plane Sections Required	Type of Sections Used			
			AB-21/GR	AB-22/GR	AB-23/GR	AB-24/GR		AB-21/GR	AB-22/GR	AB-23/GR	AB-24/GR
RT-246/VRC	30 to 36.5	4	2	1	1	1	15	2	1	1	1
RT-524/VRC	36.5 to 60.5	3	1	1	1	1	12	1	1	1	1
RT-505/PRC-25	60.5 to 75.95	2	0	1	1	1	9	0	1	1	1
RT-841/PRC-77											

Table 3-1. Antenna element selection chart.

### Section IV. Antenna Group OE-254/GRC

#### Description

Antenna Group OE-254/GRC is used to extend the range of the old and new generation of FM field radio sets. The antenna consists of three upward and three downward extended radials. These radials remain the same length for all frequencies from 30 to 88 MHz. The antenna is elevated on a 30-foot sectional mast held erect with guy ropes and stakes.

NOTE: No change needs to be made in the number of radials when a change of frequency is necessary.

## Antenna Group OE-254/GRC

### Installation

STEP	ACTION
------	--------

- 1 Site layout.
  - a. Position the base plate, with the ribs up, where the antenna is to be erected.
  - b. Drive the stake of the mast and base assembly (Figures 3-3 and 3-4) through the center hole of the base plate with the hammer.

#### CAUTION

Use extreme care in driving the stake with the hammer. The space between the ears of the stake is barely enough to clear the hammer. Hitting one of the ears with the hammer will break it.

- c. Drive the two pin stakes through opposite corner holes of the base plate.
- d. Assemble the five lower mast sections on the mast and base assembly.
- e. Slide the lower guy plate (color coded blue) onto the male end of the lower adapter assembly and join it to the mast.
- f. Assemble three upper mast sections on the lower adapter assembly.
- g. Walk the assembled mast around the mast and base assembly. Drive the guy stakes as shown in Figures 3-3 and 3-4.

NOTE: Make sure the area for the anchors is firm. If the ground is marshy or sandy, get specific instructions from your supervisor on how to reinforce the anchors.

- h. Return the mast and base assembly to the alignment shown in Figure 3-3.

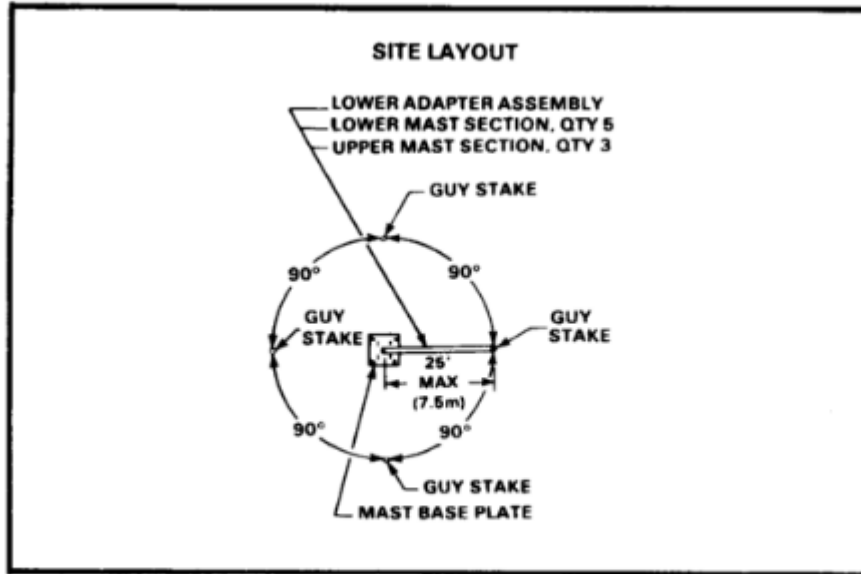

Figure 3-3. Positioning guy stakes.

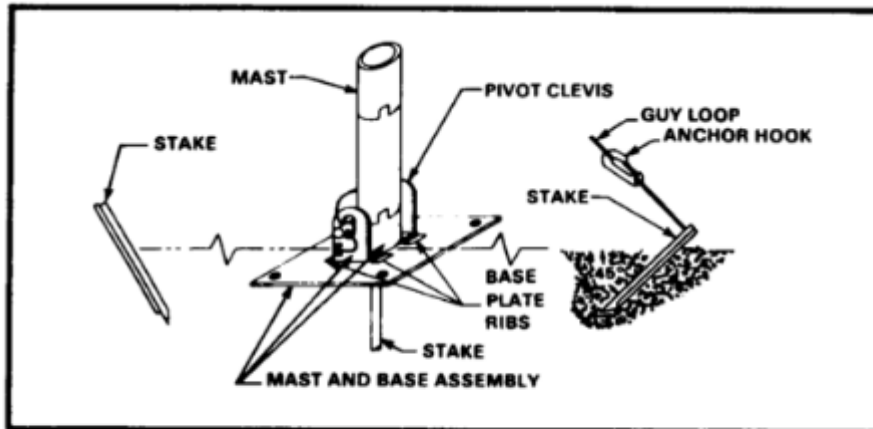

Figure 3-4. Ground anchor/pivot clevis alignment.

STEP	ACTION
2	Assemble the mast.
	a. Assemble the two remaining upper mast sections on the nine previously assembled.
	NOTE: If the antenna is not to be raised to its full height, reduce the number of mast sections. Eliminate the upper mast sections first. The lower and upper adapter assemblies and the insulating extension must be used.
	b. Slide the upper guy plate (color coded red) onto the male end of the upper adapter assembly and join it to the mast.
	c. Turn the guy plates so that one hole of each is uppermost.
3	Connect the guys.
	a. Attach the hooks of the lower guy assemblies (color coded blue) to the lower guy plate (Figure 3-5).
	b. Extend the guy assemblies to the side and back anchor hooks and attach the guy loops (Figure 3-6).
	c. Attach the hooks of the upper guy assemblies (color coded red) to the upper guy plate (Figure 3-5).
	d. Extend the upper guy assemblies to the side and back anchor hooks and attach the guy loops (Figure 3-6).
	e. Make sure that the mast assembly is laid out straight and crosses beside one guy stake (the back guy stake, Figure 3-14).
	f. Pull the upper and lower guys on each side tight (Figure 3-7) and secure them (Figure 3-8). Make sure the mast assembly is not pulled out of line.
	g. Lay the two bottom (upper and lower) guys along one of the tightened side guys and adjust them to the same length. Attach the bottom guy ropes to the back guy stake (Figure 3-14).

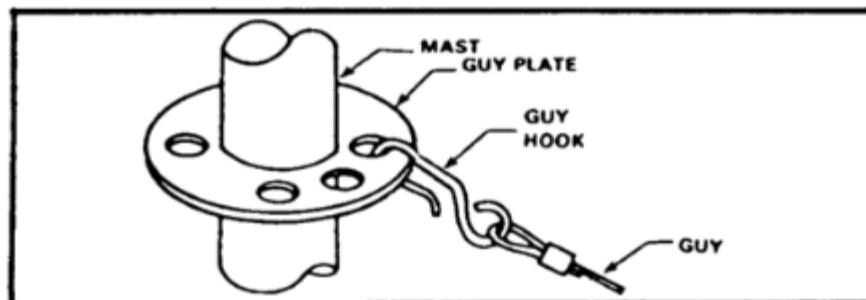

Figure 3-5. Attaching guy hooks to guy plate.

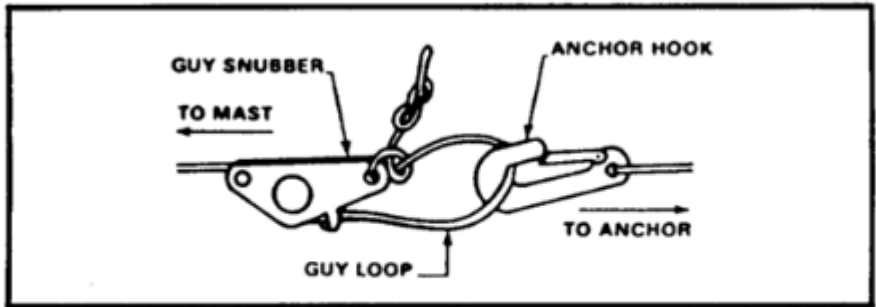

Figure 3-6. Attaching guy loops to ground anchor.

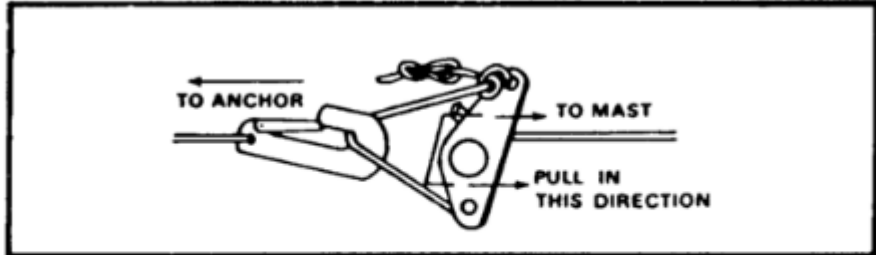

Figure 3-7. Pulling guy rope taut.

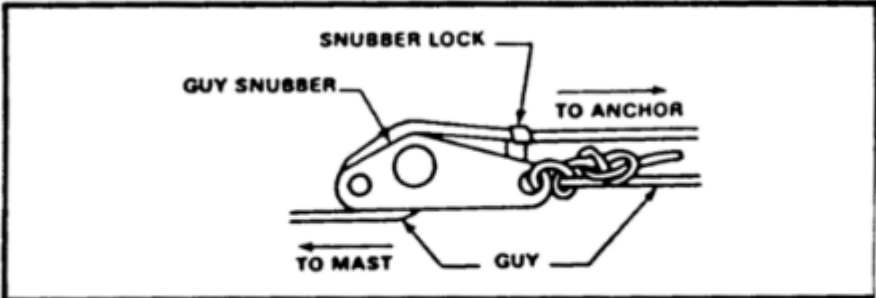

Figure 3-8. Securing guy with snubber lock.

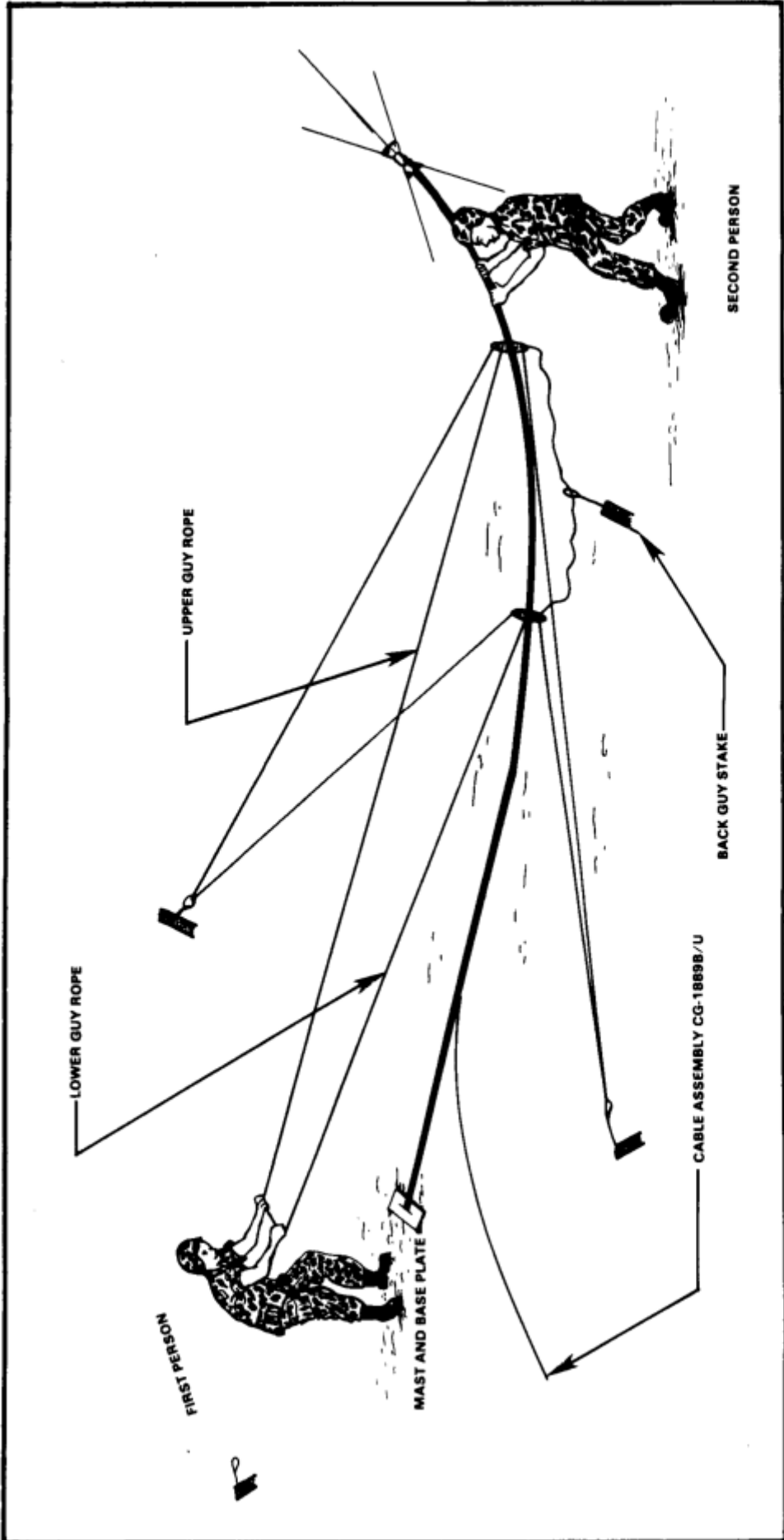

Figure 3-14. Erecting antenna group OE-254/GRC.

STEP	ACTION
------	--------

- 4 Assemble antenna elements.
  - a. Coat the threaded portion of the insulating extension with silicone compound (Figure 3-9).
  - b. Screw the insulating extension into the feed cone assembly and assemble it to the mast.
  - c. Coat the screw threads of 18 antenna elements (six each: MS-116A, MS-117A, and AB-24) with silicone compound.
  - d. Assemble six sets of antenna sections (one each: MS-116A, MS-117A, and AB-24 in each section) (Figure 3-10).
  - e. Assemble each antenna section to one of the sockets on the feed cone assembly.

NOTE: Additional weatherproofing of the antenna assembly may be made at this time by wiping the excess silicone compound from the antenna assembly and wrapping each joint with electrical tape.

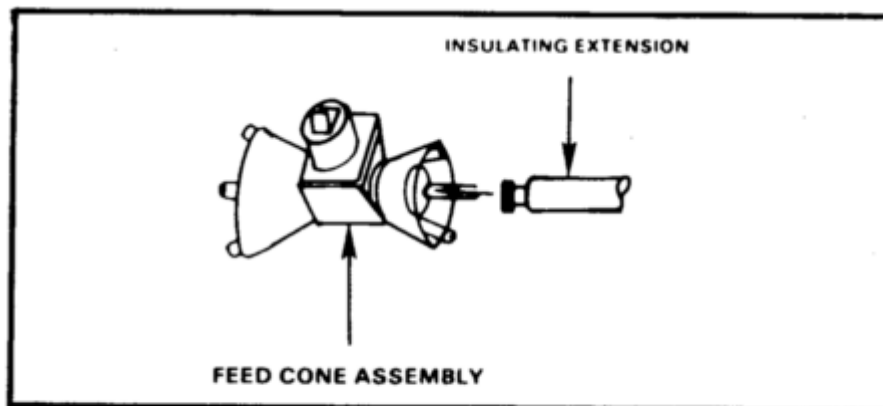

Figure 3-9. Connecting insulating extension to feed cone assembly.

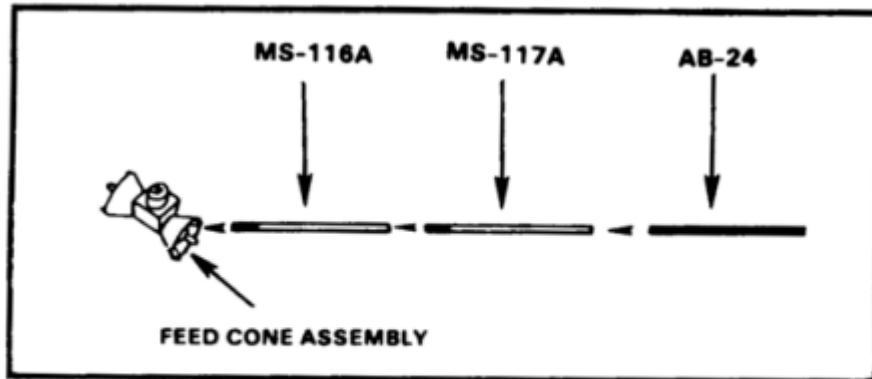

Figure 3-10. Assembling antenna elements.

STEP	UNIT	ACTION
5	Connect RF Cable Assembly CG-1889B/U.	
	a.	Unscrew the connector cap of the feed cone assembly connector and secure the cap to the connector protective bracket (Figure 3-11).
	b.	Connect the RF Cable CG-1889B/U to the feed cone assembly connector (Figure 3-12).
	c.	Compress and open the strain relief clamp. Pass the cable of the clamp through the fifth hole of the upper guy plate (Figure 3-13). Secure the cable in the clips of the clamp.
	d.	Attach the strain relief clamp to the RF cable. Close and release the clamp.
	e.	Tape the RF cable connection (Figure 3-12) and tape the cable to the insulating extension just below the feed cone assembly. Tape the cable to the mast every 5 feet all the way to the bottom of the mast.

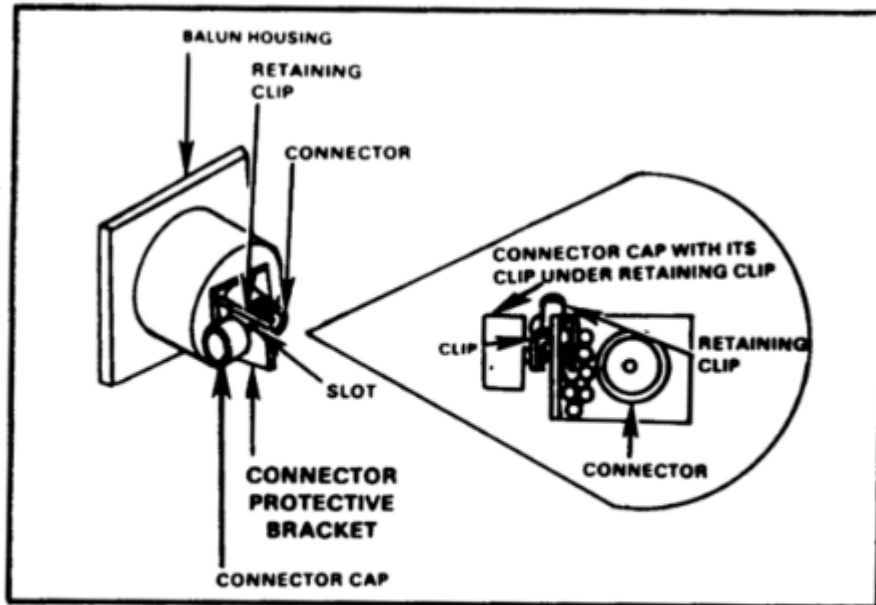

Figure 3-11. Captivating feed cone assembly connector cap.

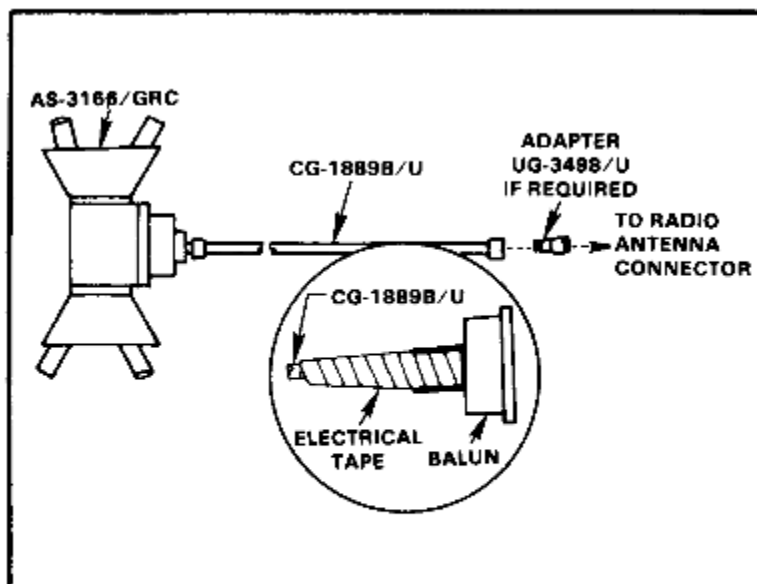

Figure 3-12. Connections of CG-1889B/U to AS-3166/GRC and radio.

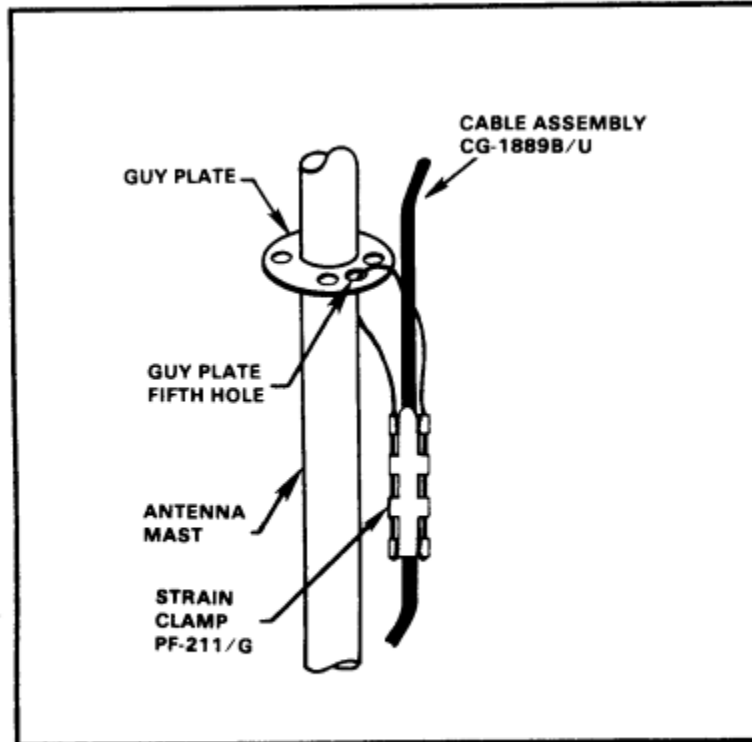

Figure 3-13. Strain clamp closed.

STEP	ACTION
------	--------

6 Erect the antenna.

**WARNING 1**

**When erecting the antenna, allow only team personnel in the erecting area.**

**WARNING 2**

**Clearly mark all guys with warning flags or signs (supplied by your unit). In an emergency, use strips of white cloth as warning streamers.**

a. Preparation.

- (1) Installer—near the baseplate assembly in line with the far guy stake holding the free guys (Figure 3-14).
- (2) Assistant—at the top holding the antenna at shoulder height.

b. Raising.

- (1) Installer—bow the top end by pulling the guys tight and walk backward pulling the mast slowly and firmly erect.
- (2) Assistant—walk toward the base pushing the mast upward.

c. Adjusting.

- (1) Connect the free guys to the remaining guy stake assembly (Figure 3-6) and tighten the guys.
- (2) Adjust all the guy ropes evenly. Check for vertical position by comparing the mast with a building, pole, or other vertical object.

**NOTE:** Leave a slight slack in each guy to allow for expansion and contraction of the mast and guys. Check the tension in the morning and during the day. Experience with temperature conditions in the area will determine how tight the guys should be.

STEP	ACTION
------	--------

**WARNING**

If the weather in your area can cause ice to form on the antenna and guys, add extra guys to support the system. Rope off the area and post it with warning signs, such as beware of falling ice. Keep a sharp eye on the anchors and guys. Check them daily and immediately before and after bad weather.

- 7 Connect the antenna.

(Refer to TM 11-5985-357-13.)

NOTE: For AN/VRC-12 family FM radios with BNC type antenna connectors, use the UG-349B/U adapter on the end of the CG-1886B/U RF cable (Figure 3-12).

### Section V. Doublet Antenna

#### Determining Doublet Antenna Length

STEP	ACTION
------	--------

- 1 Determine frequencies to be used.
- 2 Compute the lengths desired.

Use formula:

$$L = \frac{468}{F}$$

L - means length of antenna in feet and tenths of feet.

F - means frequency in MHz

Example:

$$L = \frac{468}{8.641 \text{ MHz (frequency)}}$$

$$8.641 \overline{) 468.000} \quad 54.1$$

NOTE: This formula does not apply to antennas longer than half-wave.

### Section V. Doublet Antenna

#### Determining Doublet Antenna Height

STEP	ACTION
------	--------

- 1 Determine frequency to be used.
- 2 Use formula for quarter-wave.

$$F \sqrt{\frac{H}{246}}$$

F - means frequency in MHz.  
H - height of antenna in feet.

**EXAMPLE**

$$5.7 \sqrt{\frac{43}{2460}} \quad (\text{or 8 AB-155 40 feet})$$

- 3 Use formula for tenth of a wave.

$$F \sqrt{\frac{H}{98.4}}$$

F - means frequency in MHz.  
H - height of antenna in feet.

**EXAMPLE**

$$5.7 \sqrt{\frac{17}{98.4}} \quad (\text{or 3 AB-155 15 feet})$$

The height of the doublet antenna above the ground determines the radiation pattern, or take-off angle. The radiation pattern for a distance of 0 to 250 miles should be straight up. To determine the height of your doublet antenna, use OTF. For daytime uses of 4.8 to 9.7 MHz for a distance of 100 miles, use the formula for a quarter-wave. For nighttime uses of the same frequency of 4.8 to 9.7 MHz, use the formula for a tenth of a wave.

## Doublet Antenna

### Orientation

STEP	ACTION
<b>WARNING</b>	
<b>When making adjustments to an antenna, the transmitter on the radio set must be off.</b>	
1	The radiation pattern of the doublet antenna will be broadside when the fundamental half-wavelength is used. (Use a compass for accurate determination of the antenna orientation.)
2	Stretch the antenna wire along the ground broadside to the weakest distant station.
3	Place the end masts several feet beyond the end insulators.
4	<p>The center mast should be at the coaxial connector and offset 3 feet from the line between the two end masts.</p> <p>a. This allows the antenna to clear the center mast.</p> <p>b. A center mast is not required if the antenna is less than 120 feet.</p>
5	Guy plates are installed on mast sections number 3, 5, and 8.

## Doublet Antenna

### Installation Using AB-155A/U

[Figure 3-15](#) shows correct installation of a doublet antenna using mast assembly AB-155A/U. Pay particular attention to mast height. For maximum effectiveness, erect a doublet antenna at least a quarter-wavelength off the ground. Forty-foot masts provide adequate height in most instances.

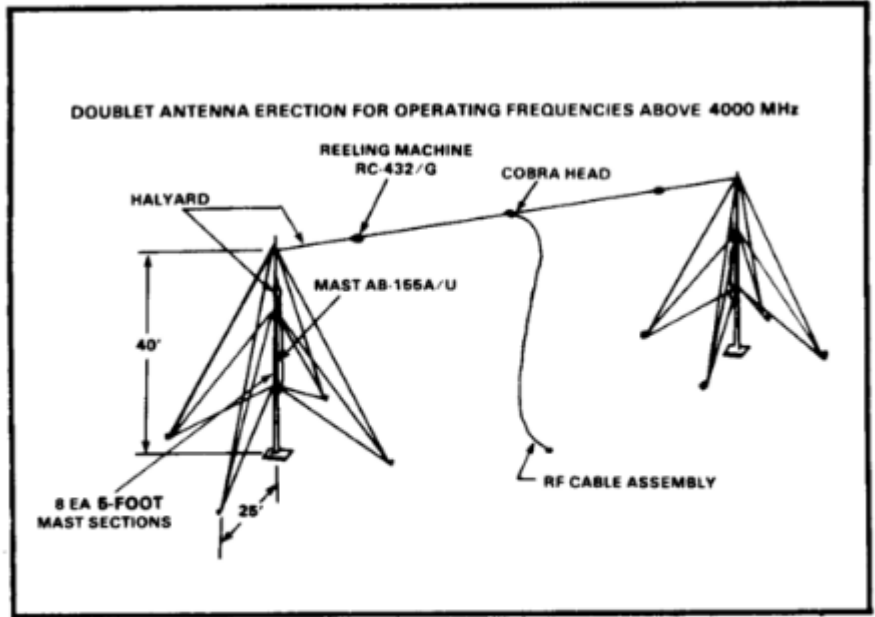

Figure 3-15. Doublet antenna installation using AB-155A/U.

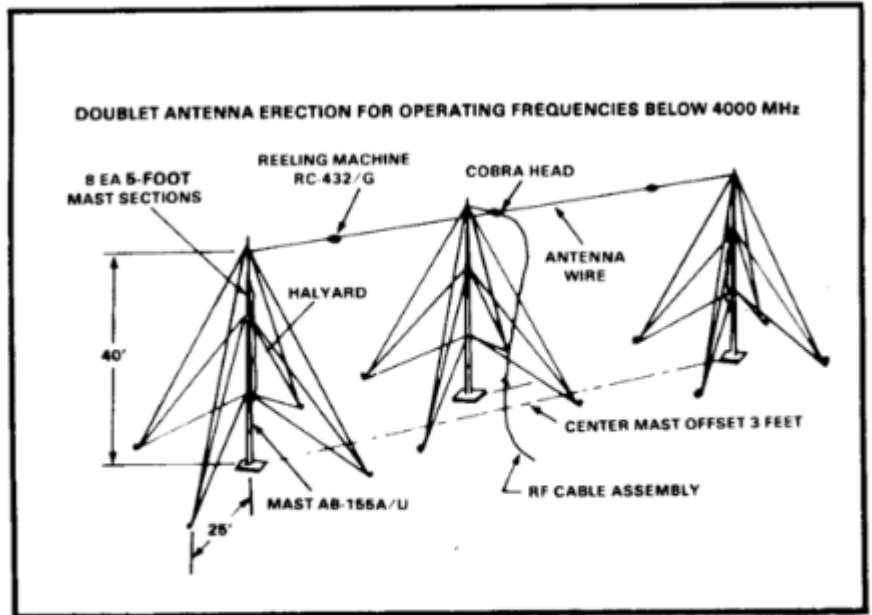
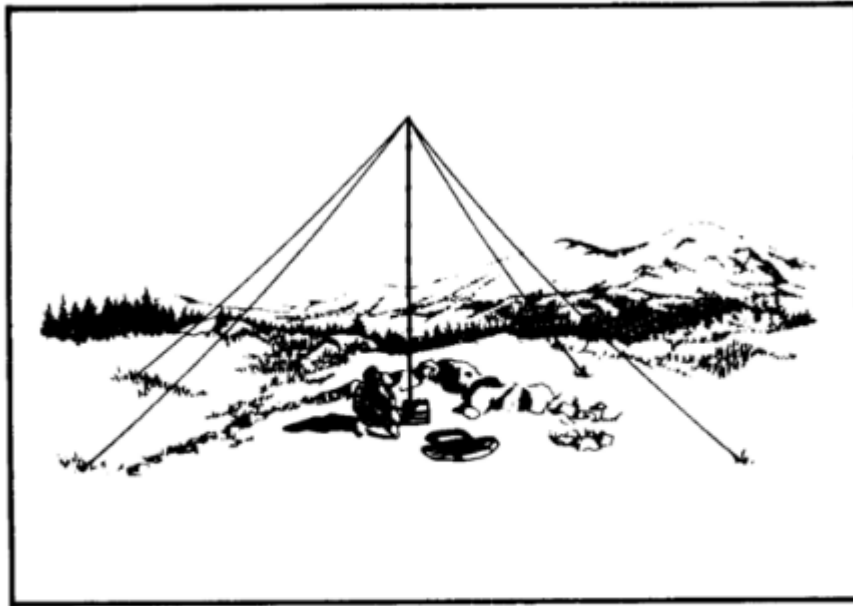

Figure 3-15. Doublet antenna installation using AB-155A/U.  
(continued)

## Section VI. NVIS Antenna AS-2259/GR

### Description

a. The NVIS Antenna AS-2259/GR is a lightweight, sloping dipole, omnidirectional antenna. It is designed to be used with an AM radio operating in the HF range of 2 to 30 MHz. It provides high angle radiation (near vertical incidence) to permit short-range sky wave propagation over communications circuits varying from 0 to 300 miles. It can be used with tactical HF radio communications equipment that tunes a 15-foot whip antenna. Examples of such equipment are the AN/GRC-106 and the IHFRs (AN/PRC-104A and AN/GRC-213/193A). [Figure 3-16](#) shows an operational AS2259/GR NVIS.



**Figure 3-16. AS-2259/GR (NVIS).**

b. An adapter MX-10618/GRC-193A is used to interface the vehicle's whip antenna base with the AS-2259/GR. Do not use the adapter MX-9313/GR provided with some of the earlier antenna kits with the AN/PRC-104A or AN/GRC-213/193A. It is used to interface radios with greater output power (AN/MRC83/87). The antenna weighs about 14.7 pounds and can be erected by two men in about 5 minutes. The antenna is polarized horizontally and vertically at the same time, radiating RF energy in all directions at the same time. It consists of eight lightweight mast sections that function as the antenna coax feed line and four radiating elements that also serve as guys supporting the mast.

## **NVIS Antenna AS-2259/GR**

### **Installation**

STEP	ACTION
1	<p>Site selection.</p> <p>An 84- by 84-foot clear area is required for installation of the AS-2259/GR antenna. Figure 3-17 shows an antenna site with inadequate distance between power lines and antenna mast.</p>
<b>DANGER</b>	
<p><b>Antennas must be separated from power lines by a distance equal to twice the height of the antenna. Antenna contact with power lines may cause serious injury or even death to the operator. Be sure transmitter power is off. Contacting the antenna when the transmitter is keyed will cause electrical burns.</b></p>	
2	<p>Ground installation.</p> <ol style="list-style-type: none"><li data-bbox="483 772 1255 835">a. Open antenna pack. Remove antenna base (Figure 3-19) and place it on the ground.</li><li data-bbox="483 852 1255 915">b. Remove top mast assembly (Figure 3-19) and install it on the antenna base.</li><li data-bbox="483 932 1255 1062">c. Uncoil the antenna elements and stretch them in the direction in which they leave the top housing. Ensure the elements are not shorted to each other or to the housing. If necessary, adjust the direction of the elements.</li><li data-bbox="483 1079 1255 1182">d. Measure anchor positions using the sleeve cable markers as guides and install guy stakes as shown in Figure 3-20. Leave slack in the elements lying on the ground.</li></ol>
<p><b>NOTE:</b> Before assembling mast sections, wipe unpainted surfaces clean of mud or dirt to ensure good electrical contact.</p>	

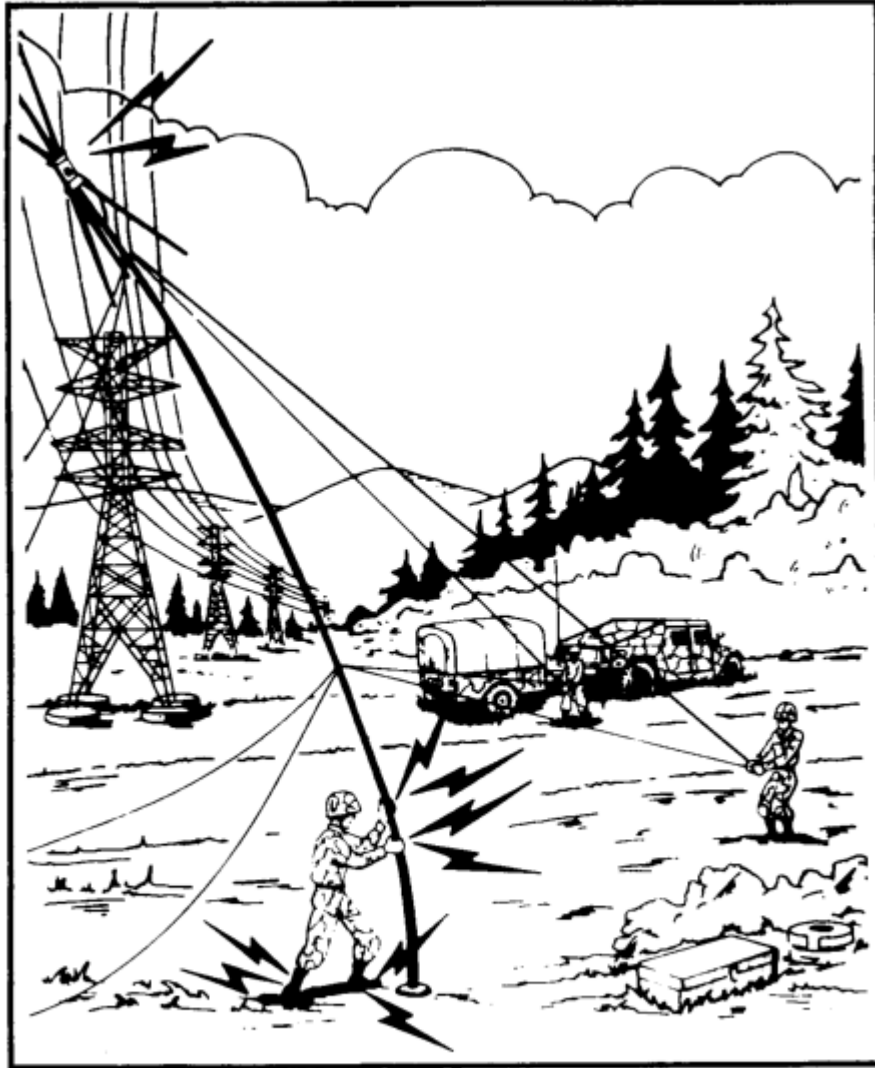

Figure 3-17. Antenna site with inadequate distance between power lines and antenna mast.

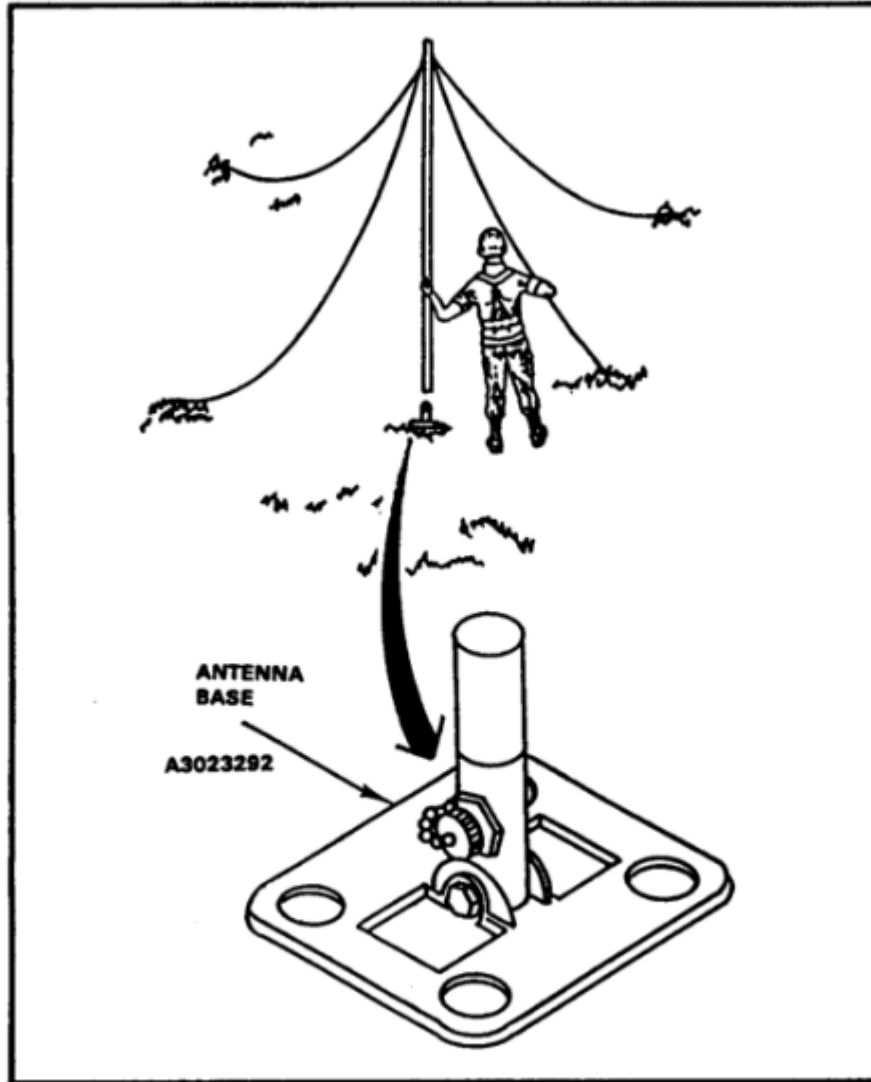

Figure 3-19. AS-2259/GR antenna top mast assembly installation.

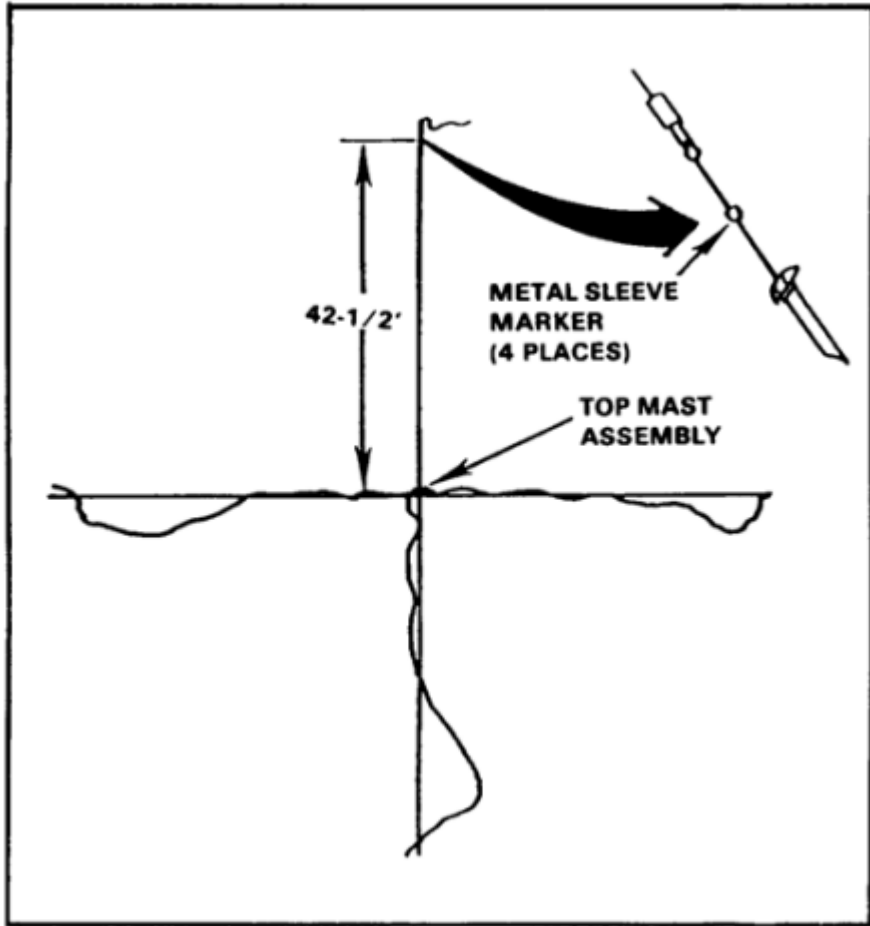

Figure 3-20. Guy stake installation.

- e. Assemble mast by raising the top mast assembly vertical to the ground and by inserting each of the seven 22-inch sections into the bottom of the previous section. Continue to lift upward on the mast as each section is installed. Insert the bottom section of the mast onto the mast base (Figure 3-18) by lowering it into place.
- f. Adjust tension on all elements until mast is vertical and straight. Elements need not be excessively taut (3 to 5 pounds of tension).

**3 Vehicular installation.**

Install the AS-2259/GR antenna on vehicular mounts the same as above, except use the vehicular whip mount. Use the Adapter MX-10618 instead of the base assembly. Use only the number of mast sections needed to raise the top of the antenna to about 16 feet.

**NOTE:** Do not use the Adapter MX-9313/GR that may be in earlier models of the AS-2259/GR with any of the IHFR systems. Use the MX-10618 with IHFR sets.

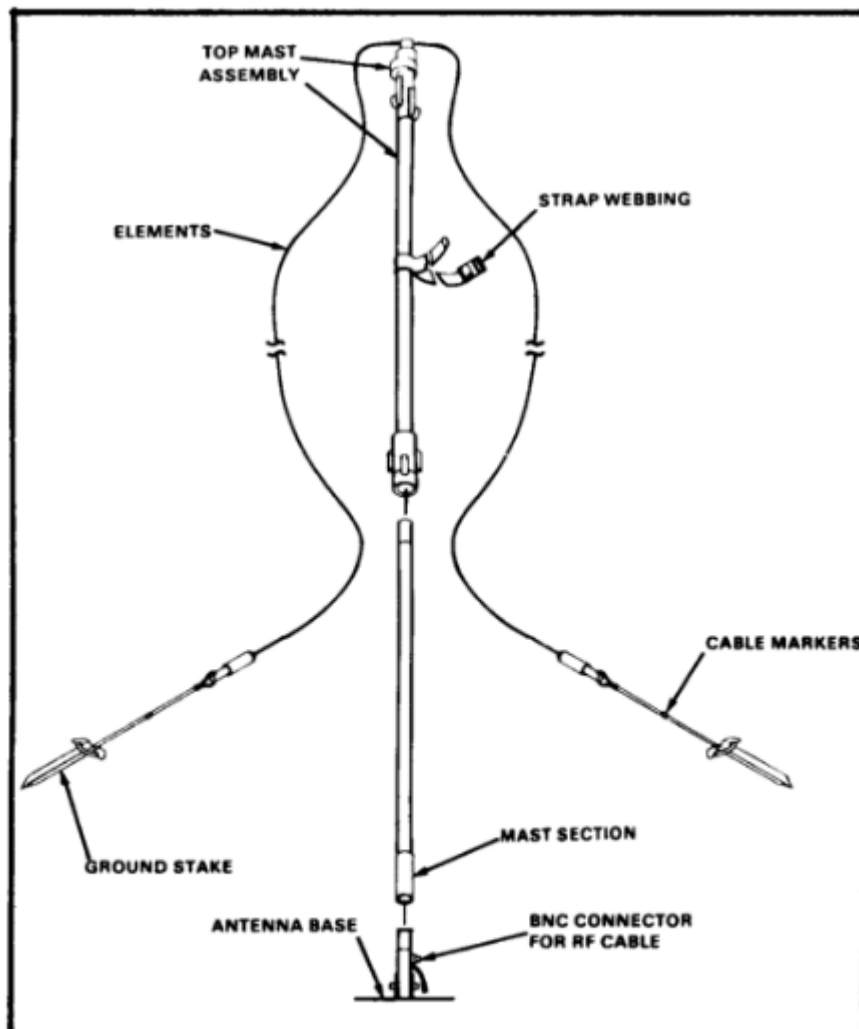

Figure 3-18. AS-2259/GR antenna base.

## Section VII. Field Expedients for Antennas

a. Antennas are sometimes broken or damaged resulting in failed or poor communications. If a spare is available, replace the damaged antenna. When there is no spare, fabricate an emergency antenna. For more information on how to repair and fabricate antennas refer to [FM 24-18](#). The following suggest ways to construct an emergency antenna.

- (1) The best wire for antennas is copper or aluminum. In an emergency, however, use any wire available. WD-1/TT is suitable for this purpose.
- (2) The exact length of many antennas is critical. Therefore, the length of the emergency antenna should be the same as the length of the antenna it replaces.

(3) Antennas supported by trees can usually survive heavy windstorms if the trunk of a tree or a stout limb is used for support. To keep the antenna taut and to prevent it from breaking or stretching, attach a spring or a strip of old inner tube to one end of the antenna, or pass a rope through a pulley or eye hook, attach the rope to the end of the antenna, and load the rope with a heavy weight to keep the antenna taut.

(4) Guys used to hold antenna supports are made of rope or wire. To ensure that wire guys will not affect the operation of the antenna, cut the wire into several short lengths and connect the pieces with insulators. Small pieces of dry wood, bottles, or even suitably shaped stones may be used.

b. An improvised antenna may change the performance of a radio set. Use either of the two following expedient methods to determine whether the improvised antenna is operating properly.

(1) The distant receiver may be used to test the antenna. If the signal received from a station is strong, the antenna is operating satisfactorily. If the signal is weak, adjust the height and length of the antenna and transmission line to receive the strongest signal at a given setting of the volume control of the receiver. If your set is equipped with a power or SWR meter, use this device to adjust your antenna.

(2) In some radio sets, the transmitter is used to adjust the antenna. First, set the controls of the transmitter in the proper position for normal operation; then, tune the system by adjusting the antenna height, length, and the transmission line length to obtain the best transmission output.

c. When a whip antenna is broken into two sections, the portion of the antenna that is broken off can be connected to the portion attached to the base fitting by joining the sections together. When both parts of the broken whip are available and usable, connect the two broken ends together and wrap with wire, ensuring that wrapping is clean and tight. Lash pole or branch to antenna until antenna will stand alone. When the portion of whip that is broken is missing or unusable, add a piece of wire that is nearly the same length as the broken section. Then, lash a pole the length of the antenna securely to the base section of the antenna and tie wire to the top of pole. If possible, solder the connections.

d. Emergency repair of wire antennas can be grouped into two categories: repair or replacement of the wire used as an antenna or transmission line; and repair or replacement of the assembly used to support the antenna wires.

(1) When one or more wires on an antenna are broken, the antenna can be repaired by reconnecting the broken wires. To do this, lower the antenna to the ground, clean the surface of the wire, and twist the wires together. Whenever possible, solder the connections.

(2) If the antenna is damaged beyond repair, substitute another antenna. If antenna sections are not available, WD-1 (field wire) can be used as a substitute. Ensure the length of the wire is the same length as the original antenna and you have a good wire to antenna contact.

e. Building a good field-expedient vertical half-rhombic antenna calls for a good resistor, not a dead BA-30 battery or a C-rat can full of sand and oil. Plan ahead. If you can, lay in a supply of the 600-ohm 2-watt resistors. Since 600-ohms is not a standard resistor value, you have a choice. Get a 620-ohm, 2-watt with NSN 5905-00-407-6167, or wire 2 1200-ohm, 1-watt resistors in parallel. Get them with NSN 5905-00-369-6916. Then, follow the directions on how to fabricate antennas. Put the resistor on the end nearest your receiving station. Remember, resistor wattage must beat least half of the radio's output wattage. (See [Figure 3-21.](#))



Figure 3-21. Proper resistor.

## Section VIII. Grounding Systems

STEP	ACTION
1	<p><b>Ground Rods.</b></p> <ul style="list-style-type: none"> <li>a. Dig a hole 6 to 8 inches deep and 18 inches wide.</li> <li>b. Drive ground rod until rod is about 3 inches above bottom of hole.</li> <li>c. Connect ground strap to clamp or terminal (see note).</li> <li>d. Fill hole with water (salt water, if possible).</li> <li>e. After water soaks in, fill hole with dirt.</li> </ul>
2	<p><b>Underground Objects.</b></p> <p style="text-align: center;"><b>WARNING</b></p> <p><b>If underground pipes or tanks are used, ensure they do not contain gasoline, oil, or other flammable liquids or gas.</b></p> <ul style="list-style-type: none"> <li>a. Buried pipes, steel building frames, metal poles, storage tanks, and other similar underground objects may be used for grounding system.</li> <li>b. Connect ground strap. If no bolt or screw is available, use clamp to connect ground strap (see note).</li> <li>c. Ensure underground object is metal not plastic.</li> </ul>
3	<p><b>Ground Plates.</b></p> <ul style="list-style-type: none"> <li>a. Use a 3- by 3-foot or larger metal plate. Heavy mesh such as a section of chain link fence may also be used.</li> <li>b. Drill a hole in center of plate and fasten ground strap with bolt or screw.</li> </ul> <p>c. Dig pit at least 4 feet deep and lay plate inside.</p> <p>d. Fill hole with dirt and soak with water.</p>
	<p><b>NOTE:</b> Use the "wrap method" if a terminal screw or a ground clamp is not available. Bind the ground strap to the rod by using strong, flexible bare wire. Wrap about 24 turns of the wire around the strap and the rod, then solder the wire and strap to the rod. If solder is not available, twist the ends of the wire as tight as you can, then tape the connection to keep out moisture.</p>